



AC-DC 30W

6A-301WSXX

Level VI CoC Tier 2

WALL-MOUNT
(Fixed type)

Features:

- IEC/EN/UL/CUL 62368
- Universal AC Input 90~264Vac
- Regulated Output With Low Ripple Noise
- 100% burn in test
- 1 year warranty
- CEC,DoE Level VI,ErP Stage 2,CoC Tier 2,GEMS
- WEEE / ROHS 2.0 / REACH 2.0
- Safety : CE,CB

Dimension:

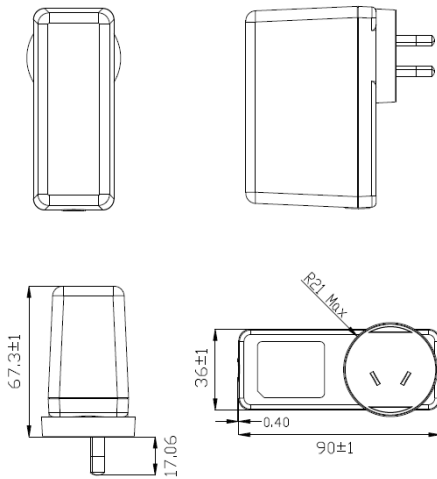

Model No.	O/P Voltage	O/P Current	O/P Watts
6A-301WS12	12V	2.5A	30.0W
6A-301WS15	15V	2.0A	30.0W
6A-301WS19	19V	1.6A	30.4W
6A-301WS20	20V	1.5A	30.0W
6A-301WS24	24V	1.25A	30.0W

Specification:

Input	Voltage	AC 90V~264V Universal Full Range
	Frequency	47-63Hz
	Current	1.0A
	Leakage Current	< 0.25mA
Others Protection	Start up time	< 3000mS @115VAC Full Load
	Rise time	<100mS
	Hold up time	>15mS @ 230Vac/50Hz input
	Protection	OCP/OVP/SCP
	Cooling	Natural Convection Cooling
Environment	Temperature	Operating: 0~40°C;Storage: -10~+70°C
	Humidity	Operating: 20%~85%;Storage: 10%~95%(Non Condensing)
M.T.B.F	50K Hours MIL-HDBK-217F @115VAC/ 230VAC Full Load Ambient : 25°C	
Safety Regulation	UL 62368-1, CSA C22.2 No.62368-1, IEC62368-1, EN62368-1	
EMC	EMI	FCC CFR 47 PART 15B, EN55032, EN61000-3
	EMS	EN55024(EN61204-3), EN61000-4
Energy Efficiency	Average active efficiency	30W > 86.95% Min @230Vac / 50Hz input ; 30.4W > 86.99% Min @230Vac / 50Hz input
	Efficiency at low load (10 %)	30W > 76.95% Min @230Vac / 50Hz input ; 30.4W > 76.99% Min @230Vac / 50Hz input
	No-load power consumption	> 0.1W Min @ 230Vac / 50Hz input

英格爾科技股份有限公司
ENG ELECTRIC CO.,LTD.

台灣桃園市龜山區民生北路1段536號5樓
5F., No. 536, Sec. 1, Minsheng N. Rd.,
Gueishan Dist., Taoyuan City 333016,
Taiwan (R.O.C.)



TEL:886-3-212-1122 FAX:886-3-212-1570 E-mail:eng@eng.com.tw http://www.eng.com.tw

